

Article Info

Received: 30 Jul 2020 | Revised Submission: 20 Oct 2020 | Accepted: 28 Oct 2020 | Available Online: 15 Dec 2020

Drilling and Sawing Machines and their Operations: Review

*Rishabh Sharma**, *I. A. Chauhan*** and *J. B. Raol****

ABSTRACT

The review of this paper pertaining to the present research topic has been carried out to gain knowledge and to become familiar with the established techniques and methodology. Drilling Machine designed to produce a cylindrical hole of required diameter and depth on metal workpieces. Though holes can be made by different machine tools in a shop, drilling machine is designed specifically to perform the operation of drilling and similar operations. Drilling can be done easily at a low cost in a shorter period of time in a drilling machine. Sawing is a process in which a narrow slit is cut into the work by a tool called saw consisting of a series of narrowly spaced teeth. Each tooth removes a small amount of material with each stroke or movement of the saw. Each tooth forms a chip progressively as it passes through the workpiece. This project presents the concept of Multi-Function Operating Machine mainly carried out for production-based industries.

Keywords: *Drilling; Sawing; Drilling operations; Sawing operation; Workshop; Machine tools.*

1.0 Introduction

Drilling machine is one of the most important machine tools in a workshop. It was designed to produce a cylindrical hole of required diameter and depth on metal workpieces. Though holes can be made by different machine tools in a shop, drilling machine is designed specifically to perform the operation of drilling and similar operations. Drilling can be done easily at a low cost in a shorter period of time in a drilling machine. Drilling can be called as the operation of producing a cylindrical hole of required diameter and depth by removing metal by the rotating edges of a drill. The cutting tool known as drill is fitted into the spindle of the drilling machine. A mark of indentation is made at the required location with a centre punch. The rotating drill is pressed at the location and is fed into the work. The hole can be made upto a required depth.

2.0 Construction of a Drilling Machine

The basic parts of a drilling machine are a base, column, drill head and spindle. The base made of cast iron may rest on a bench, pedestal or floor

depending upon the design. Larger and heavy-duty machines are grounded on the floor. The column is mounted vertically upon the base. It is accurately machined and the table can be moved up and down on it. The drill spindle, an electric motor and the mechanism meant for driving the spindle at different speeds are mounted on the top of the column. Power is transmitted from the electric motor to the spindle through a flat belt or a 'V' belt.

2.1 Types of drilling machines

Drilling machines are manufactured in different types and sizes according to the type of operation, amount of feed, depth of cut, spindle speeds, method of spindle movement and the required accuracy.

The different types of drilling machines are:

1. Portable drilling machine (or) Hand drilling machine
2. Sensitive drilling machine (or) Bench drilling machine
3. Upright drilling machine
4. Radial drilling machine
5. Gang drilling machine
6. Multiple spindle drilling machine
7. Deep hole drilling machine

*Corresponding author; Dairy Engineering Department, SMC College of Dairy Science, Anand Agricultural University, Anand, Gujarat, India (E-mail: sharmarishabh230429@gmail.com)

**Dairy Engineering Department, SMC College of Dairy Science, Anand Agricultural University, Anand, Gujarat, India

***SAU Council, Gandhi Nagar, Gujarat, India

2.2 Portable drilling machine

Portable drilling machine can be carried and used anywhere in the workshop. It is used for drilling holes on workpieces in any position, which is not possible in a standard drilling machine. The entire drilling mechanism is compact and small in size and so can be carried anywhere. This type of machine is widely adapted for automobile built-up work. The motor is generally universal type.

These machines can accommodate drills from 12mm to 18 mm diameter. Portable drilling machines are operated at higher speeds.

2.3 Sensitive drilling machine

It is designed for drilling small holes at high speeds in light jobs. High speed and hand feed are necessary for drilling small holes. The base of the machine is mounted either on a bench or on the floor by means of bolts and nuts. It can handle drills upto 15.5mm of diameter. The drill is fed into the work purely by hand. The operator can sense the progress of the drill into the work because of hand feed. The machine is named so because of this reason. A sensitive drilling machine consists of a base, column, table, spindle, drill head and the driving mechanism.

2.4 Base

The base is made of cast iron and so can withstand vibrations. It may be mounted on a bench or on the floor. It supports all the other parts of the machine on it.

2.5 Column

The column stands vertically on the base at one end. It supports the work table and the drill head. The drill head has drill spindle and the driving motor on either side of the column.

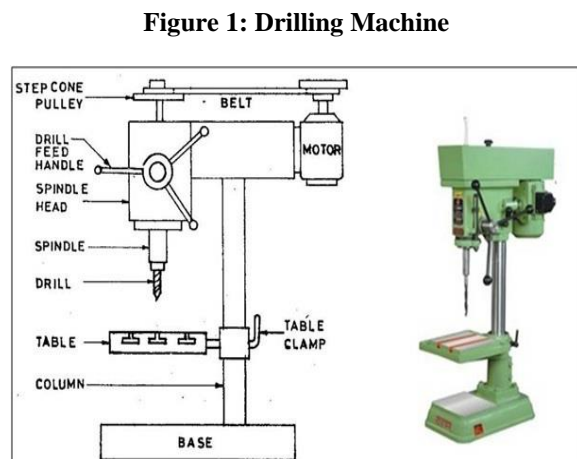

The table is mounted on the vertical column and can be adjusted up and down on it. The table has ‘T’- slots on it for holding the workpieces or to hold any other work holding device. The table can be adjusted vertically to accommodate workpieces of different heights and can be clamped at the required position.

2.6 Drill head

Drill head is mounted on the top side of the column. The drill spindle and the driving motor are connected by means of a V-belt and cone pulleys. The motion is transmitted to the spindle from the motor by the belt. The pinion attached to the handle meshes with the rack on the sleeve of the spindle for providing the drill the required down feed. There is no power feed arrangement in this machine. The spindle rotates at a speed ranging from 50 to 2000 r.p.m.

2.7 Upright drilling machine

The upright drilling machine is designed for handling medium sized workpieces. Though it looks like a sensitive drilling machine, it is larger and heavier than a sensitive drilling machine. Holes of diameter upto 50mm can be made with this type of machine. Besides, it is supplied with power feed arrangement. For drilling different types of work, the machine is provided with a number of spindle speeds and feed.

2.8 Radial drilling machine

Figure 2: Upright Drilling Machine

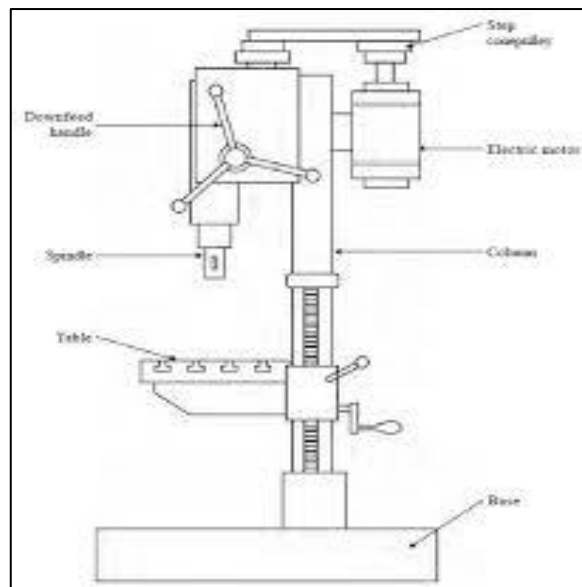

The radial drilling machine is intended for drilling on medium to large and heavy workpieces. It has a heavy round column mounted on a large base. The column supports a radial arm, which can be raised or lowered to enable the table to accommodate workpieces of different heights. The arm, which has the drill head on it, can be swung around to any position. The drill head can be made to slide on the radial arm. The machine is named so because of this reason. It consists of parts like base, column, radial arm, drill head and driving mechanism.

Figure 3: Radial Drilling Machine

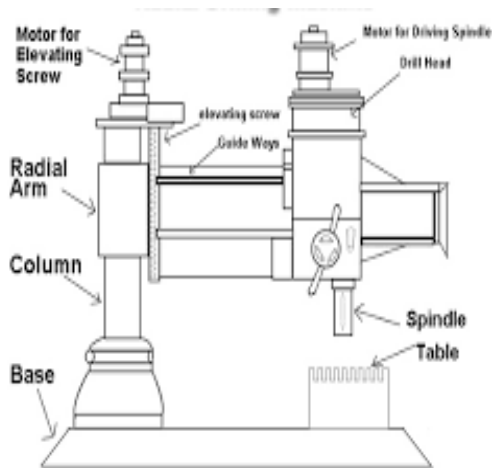

2.9 Gang drilling machine

Gang drilling machine has a long common table and a base. Four to six drill heads are placed side by side. The drill heads have separate driving motors. This machine is used for production work. A series of operations like drilling, reaming, counter boring and tapping may be performed on the work by simply shifting the work from one position to the other on the work table. Each spindle is set with different tools for different operations.

2.10 Multiple spindle drilling machine

This machine is used for drilling a number of holes in a workpiece simultaneously and for reproducing the same pattern of holes in a number of identical pieces. A multiple spindle drilling machine also has several spindles. A single motor using a set of gears drives all the spindles. All the spindles holding the drills are fed into the work at the same time. The distances between the spindles can be altered according to the locations where holes are to be drilled. Drill jigs are used to guide the drills.

2.11 Deep hole drilling machine

A special machine and drills are required to drill deeper holes in barrels of gun, spindles and connecting rods. The machine designed for this purpose is known as deep hole drilling machine. High cutting speeds and less feed are necessary to drill deep holes. A non rotating drill is fed slowly into the rotating work at high speeds. Coolant should be used while drilling in this machine. There are two different types of deep hole drilling machines

3.0 Size of a drilling machine

Drilling machines are specified according to their type. To specify the machine completely the following factors are considered:

1. Maximum diameter of the drill that it can handle
2. Size of the largest workpiece that can be centred under the spindle
3. Distance between the face of the column and the axis of the spindle
4. Diameter of the table
5. Maximum travel of the spindle
6. Numbers and range of spindle speeds and feeds available
7. Morse taper number of the drill spindle
8. Floor space required
9. Weight of the machine
10. Power input is also needed to specify the machine completely.

3.1 Work holding devices

The work should be held firmly on the machine table before performing any operation on it. As the drill exerts very high quantity of torque while rotating, the work should not be held by hand. If the workpiece is not held by a proper holding device, it will start rotating along with the tool causing injuries to the operator and damage to the machine.

Figure 4: Work Holding Devices



The devices used for holding the work in a drilling machine are

1. Drill vise
2. 'T' - bolts and clamps
3. Step block
4. V – block
5. Angle plate
6. Drill jigs

4.0 Tools Used in a Drilling Machine

Different tools are used for performing different types of operations. The most commonly used tools in a drilling machine are

1. Drill
2. Reamer
3. Counter bore
4. Countersink
5. Tap

4.1 Drill

A drill is a tool used to originate a hole in a solid material. A helical groove known as 'flute' is cut along the length of the drill.

Different types of drills are

1. Flat Drill
2. Straight fluted drill
3. Twist drill
4. Centre drill

Twist drills are the type generally used in shop work. They are made of High-speed steel (HSS) or High carbon steel. There are two types of twist drills namely (i) Straight shank twist drill and (ii) Taper shank twist drill. The diameter of the straight shank drill ranges from 2 to 16mm. Taper shanks is provided on drills of larger diameter.

4.2 Reamer

The tool used for enlarging and finishing a previously drilled hole is known as a reamer. It is a multi-tooth cutter and removes smaller amount of material. It gives a better finish and accurate dimension.

4.3 Counter bore

A Counter bore is a multi-tooth cutting tool used for enlarging the top of the previously machined hole. It has three or four cutting teeth. The flutes on them may be straight or helical. Straight fluted tools are used for machining softer materials like brass and

aluminium and for short depth of cut. Helical fluted counter bores are used for longer holes.

4.4 Countersink

A countersink has cutting edges on its conical surfaces. It has a similar construction of a counter bore except for the angle of the cutting edges. The angle of countersinks will generally be 60°, 82° or 90°. It is used for enlarging the top of the holes conically.

4.5 Tap

A tap has threads like a bolt. It has three to four flutes cut across the threads. It can cut threads on the inside of a hole. The flutes on the threads form the cutting edges. It is a multi point cutting tool. It will dig into the walls of the hole as the lower part of the tap is slightly tapered. The shank of the tap is square shaped to enable it to be held by a tap wrench.

4.6 Twist drill nomenclature

4.6.1 Axis

It is the longitudinal centre line of the drill running through the centres of the tang and the chisel edge.

4.6.2 Body

It is the part of the drill from its extreme point to the commencement of the neck, if present. Otherwise, it is the part extending upto the commencement of the shank. Helical grooves are cut on the body of the drill.

4.6.3 Shank

It is the part of the drill by which it is held and driven. It is found just above the body of the drill. The shank may be straight or taper. The shank of the drill can be fitted directly into the spindle or by a tool holding device.

4.6.4 Tang

The flattened end of the taper shank is known as tang. It is meant to fit into a slot in the spindle or socket. It ensures a positive drive of the drill.

4.6.5 Neck

It is the part of the drill, which is diametrically undercut between the body and the shank of the drill. The size of the drill is marked on the neck.

4.6.6 Point

It is the sharpened end of the drill. It is shaped to produce lips, faces, flanks and chisel edge.

4.6.7 Lip

It is the edge formed by the intersection of flank and face. There are two lips and both of them should be of equal length. Both lips should be at the same angle of inclination with the axis (59°).

4.6.8 Land

It is the cylindrically ground surface on the leading edges of the drill flutes adjacent to the body clearance surface. The alignment of the drill is maintained by the land. The hole is maintained straight and to the right size.

4.6.9 Flutes

The grooves in the body of the drill are known as flutes. Flutes form the cutting edges on the point. It allows the chips to escape and make them curl. It permits the cutting fluid to reach the cutting edges.

Figure 5: Drill Nomenclature

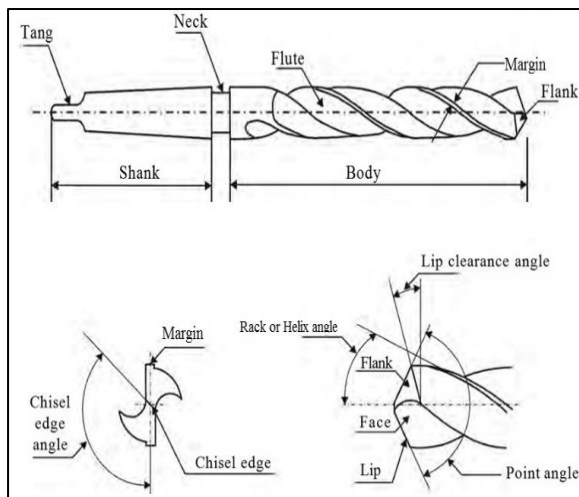

5.0 Tool Holding Devices

Different tools are used for performing different operations. They are fitted into the drill spindle by different methods. They are

1. By directly fitting in the spindle
2. By a sleeve
3. By a socket
4. By a chuck
5. Tapping attachment

Figure 6: Tool Holding Devices

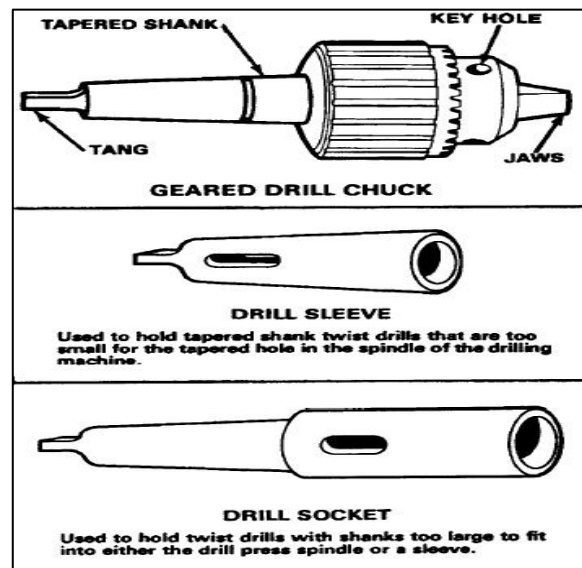

5.1 Drilling machine operations

Though drilling is the primary operation performed in a drilling machine, a number of similar operations are also performed on holes using different tools. The different operations that can be performed in a drilling machine are:

1. Drilling
2. Reaming
3. Boring
4. Counter boring
5. Countersinking
6. Spot facing
7. Tapping
8. Trepanning

Figure 7: Drilling, Boring and Reaming

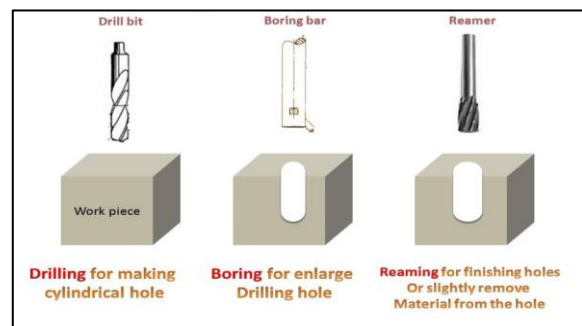

6.0 Sawing Machines

Sawing is a process in which a narrow slit is cut into the work by a tool called saw consisting of a

series of narrowly spaced teeth. Each tooth removes a small amount of material with each stroke or movement of the saw. Each tooth forms a chip progressively as it passes through the workpiece. The chips are contained within the spaces between successive teeth until the teeth pass from the work. It can be used for all metallic and nonmetallic materials and is capable of producing various shapes. It is one of the most economical means of cutting metal. Sawing is normally used to separate a work part (bar stocks, tubing, pipes,) into two pieces, or to cut off an unwanted portion of a part (Cutoff operations). In most sawing operations, the work is held stationary and the saw blade is moved relative to it.

Figure 8: Sawing Machine



6.1 Types of Sawing

1. Reciprocating saw
 - a. Manual hacksaw
 - b. Power hacksaw
2. Band saw
 - a. Vertical cutoff
 - b. Horizontal cutoff
 - c. Combination cutoff and contour
3. Circular saw
 - a. Cold saw
 - b. Abrasive Disc
 - c. Steel friction disk

6.2 Types of saw blades

Hacksaw: It is straight, relatively rigid, and of limited length, with teeth on one edge.

Bandsaw: It is sufficiently flexible that a long length can be formed into a continuous band with teeth on one edge.

Circular or cold saw: It is a rigid disk having teeth on the periphery.

6.2.1 Hack sawing

It involves a linear reciprocating motion of the saw against the work. Often used in cutoff operations. Cutting only in forward stroke of the saw blade. Due to intermittent cutting action less efficient than the continuous sawing methods. The hacksaw blade is a thin straight tool with cutting teeth on one edge. Hacksawing can be done either manually or with a power hacksaw. A power hacksaw provides a drive mechanism to operate the saw blade at a desired speed; it also applies a given feed rate or sawing pressure.

Figure 9: Hacksaw

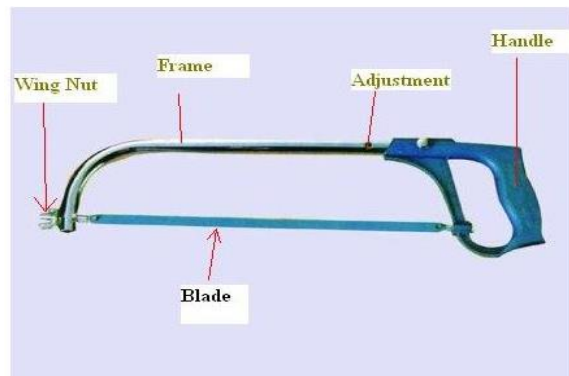

6.2.2 Band sawing

It involves a linear continuous motion, using a bandsaw blade made in the form of an endless flexible loop with teeth on one edge.

Figure 9: Bandsaw



A pulley-like drive mechanism to continuously move and guide the bandsaw blade past the work. Classified as vertical or horizontal. Vertical

bandsaws are used for cutoff as well as other operations such as contouring and slotting. Can be operated either manually, in which the operator guides and feeds the work past the bandsaw blade, or automatically, in which the work is power fed past the blade. Use of CNC to perform contouring of complex outlines. Horizontal bandsaws are normally used for cutoff operations as alternatives to power hacksaws.

6.2.3 Circular sawing

It uses a rotating saw blade to provide a continuous motion of the tool past the work. Often used to cut long bars, tubes, and similar shapes to specified length. Cutting action is similar to a slot milling operation, except that the saw blade is thinner and contains many more cutting teeth than a slot milling cutter. Circular sawing machines have powered spindles to rotate the saw blade and a feeding mechanism to drive the rotating blade into the work. Two operations related to circular sawing are abrasive cutoff and friction sawing. In abrasive cutoff, an abrasive disk is used to perform cutoff operations on hard materials that would be difficult to saw with a conventional saw blade. In friction sawing, a steel disk (no teeth) is rotated against the work at very high speeds, resulting in friction heat that causes the material to soften sufficiently to permit penetration of the disk through the work.

Fig. 10: Circular Saw

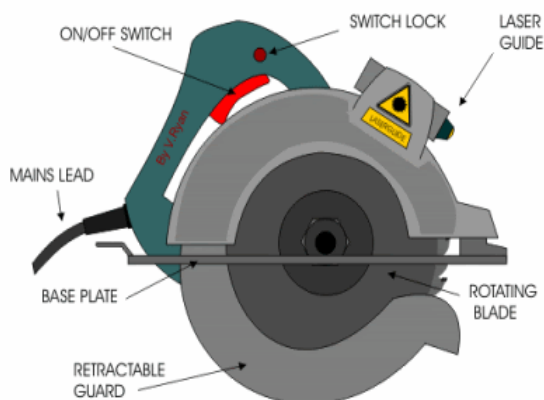

6.3 Saw blade tooth geometry

1. Width - Tip of the cutting edge to the back of the blade.
2. Thickness - Measurement taken on body (gauge).
3. Blade Body - The back of the blade to the bottom of the gullet.

4. Tooth - The cutting portion of the blade.
5. Tooth Pitch - Distance from one tooth tip to the next tip.
6. TPI - Number of teeth per inch.
7. Tooth Set - Bending of the teeth, right or left, to allow blade clearance through the cut (or kerf).
8. Tooth Face - Surface of the tooth where the chip is formed.
9. Tooth Back - the angled surface of the tooth opposite the tooth face.
10. Tooth Rake Angle - Positive (P) or Straight (S). The angle of the tooth face measured from a line perpendicular to the back of the blade.
11. Gullet - The curved area between two teeth.
12. Gullet Depth - The distance from the tooth tip to the bottom of the gullet.
13. Teeth: sharp protrusions along the cutting side of the saw.
14. Toothed edge: the edge with the teeth (on some saws both edges are toothed).
15. Back: the edge opposite the toothed edge.
16. Kerf: Width of cut

6.4 Material

Generally, are made from high-carbon and high-speed steels, Carbide, diamond or high-speed steel-tipped steel blades are used to saw harder materials. Small hacksaw blades are usually made entirely of tungsten or molybdenum high-speed steel. Blades for power-operated hacksaws are often made with teeth cut from a strip of high-speed steel that has been electron-beam-welded to the heavy main portion of the blade, which is made from tougher and cheaper alloy steel. Bandsaw blades are frequently made with this same type of construction but with the main portion of the blade made of relatively thin, high-tensile-strength alloy steel to provide the required flexibility. Bandsaw blades are also available with tungsten carbide teeth and Tin coatings

6.4.1 Tooth form

Tooth forms, or patterns, refer to the shape and pattern of the saw teeth. The three most common tooth forms are- Regular Skip tooth Hook.

6.4.2 Standard (regular) tooth form

The standard blade or regular tooth form has large radii in the gullet area of the saw teeth and a zero-rake angle. Well suited for general cutting of many types of steel and will give an accurate cut and good surface finish.

6.4.3 Hook tooth form

Positive rake angle (shaped like a hook) and large gullet area. It has a built-in chip-breaker design ideal for cutting softer materials that commonly cause chips to stick in the saw blade teeth, such as aluminum and copper.

6.4.4 Skip tooth form

Every other tooth on the skip tooth blade has been omitted. This opens up the area between the adjoining saw teeth, allowing some additional room for chip clearance. Mainly used to cut softer materials such as aluminum and brass where higher blade speeds are often used that also create a higher volume of chips.

6.4.5 Tooth spacing

It controls the size of the teeth. From the viewpoint of strength, large teeth are desirable. It determines the space between the teeth which provides room for chips removed during the cutting operation. The kerf-gullet space must be such that there is no crowding of the chip. It determines how many teeth will bear against the work. To cut the thin sections a fine pitch is again recommended, the idea is two or more teeth should remain in contact with workpiece, at a time, to prevent stripping of the teeth. Coarse pitches are required for longer cuts required in case of softer materials to accommodate the larger chips. Fine pitches are recommended for harder materials.

6.4.6 Tooth set

Staggered arrangement of the saw teeth. To provide clearance for the saw blade body as it travels through a workpiece. To make kerf wider than the blade so that blade move through the cut freely without binding or excessive frictional resistance, thus reducing the heat generated. Allows the blade to track a path accurately, following the pattern to be cut without wandering. At least two or three teeth always should be engaged with the workpiece in order to prevent snagging (catching of the saw tooth on the workpiece).

6.4.6.1 Metal sawing straight or alternate set

Teeth are offset alternatively to the right and left. Suitable for non-ferrous metals and non- metals.

6.4.6.2 Wavy set

Also called circular set. Several teeth are offset in one direction and then several other teeth are

offset in opposite direction. Employed with small teeth. Used for sawing thin sheets and sections.

6.4.6.3 Raker Set

One straight tooth is followed by two teeth set in opposite direction. used for most steel and cast-iron cutting.

6.5 Types of Sawing Machines

6.5.1 Reciprocating saw

6.5.1.1 Manual hacksaw

Operator provides reciprocating motion manually. Suitable only for small works.

6.5.1.2 Power hacksaw

Machines that mechanically reciprocate a large hacksaw blade. These machines consist of a bed, a Work holding frame, a power mechanism for reciprocating the saw frame, and feeding mechanism. Two types crank driven and hydraulically driven, Feed either by effect of force of gravity produced by the weight of saw frame, which exerts a uniform pressure or by weight clamped on frame.

Figure 11: Power Hacksaw



6.5.2 Band saw

Most commonly encountered saws. The blade is a continuous metal band with a series of teeth ground into one edge of its periphery. Two large wheels are located at opposite ends of the saw that both support and drive the saw blade. When the power is turned on, the drive wheels begin to rotate, causing the saw blade to move. The continuous blade cuts constantly, which reduces sawing time. Blades on band saws cut more accurately than reciprocating hacksaws and build up less heat. Using flexible bandsaw blades and simple flash- welding equipment, which can weld the two ends of a strip of bandsaw blade together to form a band of any desired length various efficient band sawing machines are made. Band Saw Types are-

6.5.2.1 Vertical cutoff

Blade is in a vertical orientation supported by two wheels. The uppermost wheel is an idler wheel. it supports the saw blade. it can be raised and lowered by rotating the handle located just under the wheel to adjust the tension of the saw blade. The lower wheel supports the saw blade as well and provides the driving motion to the blade. The vertical band saw is often used to rough cut a part near finished size to remove any excess material before performing other machining operations. This can drastically reduce the time and tooling needed to produce a finished product. Designed primarily for cutoff work on single stationary workpieces that can be held on a table. On many machines the blade mechanism can be tilted to about 45°, as shown, to permit cutting at an angle. They usually have automatic power feed of the blade into the work, automatic stops, and provision for supplying coolant.

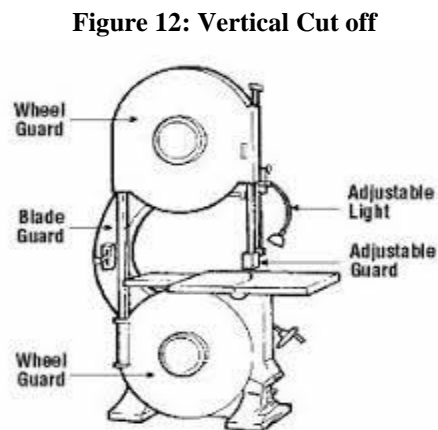

6.5.2.2 Horizontal cutoff

Blade is in a horizontal orientation. It is capable of cutting off large pieces of stock both quickly and accurately. Ideal for producing straight cuts through raw material. Use a vice to clamp material being cut. Equipped with power feeds that are controlled either hydraulically or by means of CNC. Automatic power feed of the blade into the work, automatic stops, and provision for supplying coolant. CNC bandsaws are available with automatic storage and retrieval systems for the bar stock. Because of their continuous cutting action, horizontal band sawing machines are very efficient.

6.5.2.3 Combination cutoff and contour bandsaw

Used for cutoff work or contour sawing. Used for cutting irregular shapes in connection with

making dies and the production of small numbers of parts and are often equipped with rotary tables. A table that pivots so that it can be tilted to any angle up to 45°. Have a small flash butt welder on the vertical column, so that a straight length of bandsaw blade can be welded quickly into a continuous band. The cutting speed can be varied continuously. A small grinding wheel is located beneath the welder so that the flash can be ground from the weld to provide a smooth joint that will pass through the saw guides. This welding and grinding unit makes it possible to cut internal openings in a part by first drilling a hole, inserting one end of the saw blade the rough the hole, and then butt welding the two ends together. When the cut is finished, the band is again cut apart and removed from the opening. A method of power feeding the work is provided, sometimes gravity-actuated. It made in a wide range of sizes.

6.5.3.Circular saws

6.5.3.1 Cold saw

Circular saw with metallic toothed blade designed to cut metal. Available in both portable and fixed type. Heat generated transferred to chips created, blade and material remain cool. Solid high-speed steel (HSS) or tungsten carbide -tipped, re sharpenable circular saw blade. An electric motor and a gear reduction unit to reduce the saw blade's rotational speed while maintaining constant torque. This allows the HSS saw blade to feed at a constant rate with a very high chip load per tooth. Capable of machining most ferrous and non-ferrous alloys. Minimal burr production, fewer sparks, less discoloration and no dust. Lower blade speed produce curled metal chips instead of fine dust, they cut cooler, do not affect the heat treatment of the work, and are more accurate. Offer some advantages over band saws, such as producing smooth surface finishes, very little blade "walking" or flexing, and the ability to cut thin sections with less tooth damage.



6.5.3.2 Abrasive cutoff saw

Also known as a cut-off saw or chop saw. Used to cut hard materials, such as metals, tile, and concrete using thin abrasive disc. Table top, free hand, and walk behind models are available. A high-speed motor with abrasive cutting disc mounted to its shaft that can produce cuts very quickly. It abrades the metal and generates a great deal of heat which is absorbed by the material being cut and saw blade. Both the material being cut and blade expand by heat generated through friction, resulting in increased blade wear and greater energy consumption. Dust and sparks created are harmful. Can heat up the workpiece and can change heat treatment of the same metals near the cut. Chop saws are occasionally used in the machining environment, but they see most of their use in the welding and fabrication fields.



6.5.3.3 Steel friction disc

These saws consist of a steel disc that rotates at high peripheral speeds (6000-7500 m/min). The heat produced at the mating surface due to friction melts the part through the path being cut. The saw blade then pulls the molten material out of the kerf. Blades do not need to be sharp; have no teeth—only occasional notches in the blade to aid in removing the metal. Very quick process and materials with cross sections as high as 600 mm² can be cut in about half a minute. To provide side clearance and reduce friction, cutting discs are usually provided with indentations on their circumference, commonly 2.0-3.0 mm deep. Stainless steels and tool steels can be cut more easily than high carbon steels by this process. Almost any material, including ceramics, can be cut by friction sawing.



6.6 Advantages of sawing

1. Speed of cutting
2. Low wastage of material as the width of cut (kerf) very small
3. Good quality of dimensional accuracy
4. Low power consumption.

References

- [1] VB Bhandari. Design of Machine Elements, TMH Publishers, New Delhi, 2nd Edition, 2013.
- [2] RK Jain. Machine Design, Khanna Publishers, New Delhi.
- [3] JE Shigely. Mechanical Engineering Design, TMH Publishers, New Delhi, 9th Edition, 2010.
- [4] RK Jain, SC Gupta. Production Technology, Khanna Publishers, 17th Edition, 2012.
- [5] T Moriwaki. Trends in Recent Machine Tool Technologies, Professor Department of Mechanical Engineering, Kobe University, NTN Technical Review No.74, 2006.
- [6] D Chaithanya. A Research on Multi Purpose Machine, International Journal for Technological Research in Engineering, 1(1).
- [7] H Arnold. The recent history of the machine tool industry and the effects of technological change. University of Munich, Institute for Innovation Research and Technology Managem.